

DINGS'

Precision Motion Specialist

SLOTLESS BLDC MOTOR PRODUCT CATALOG

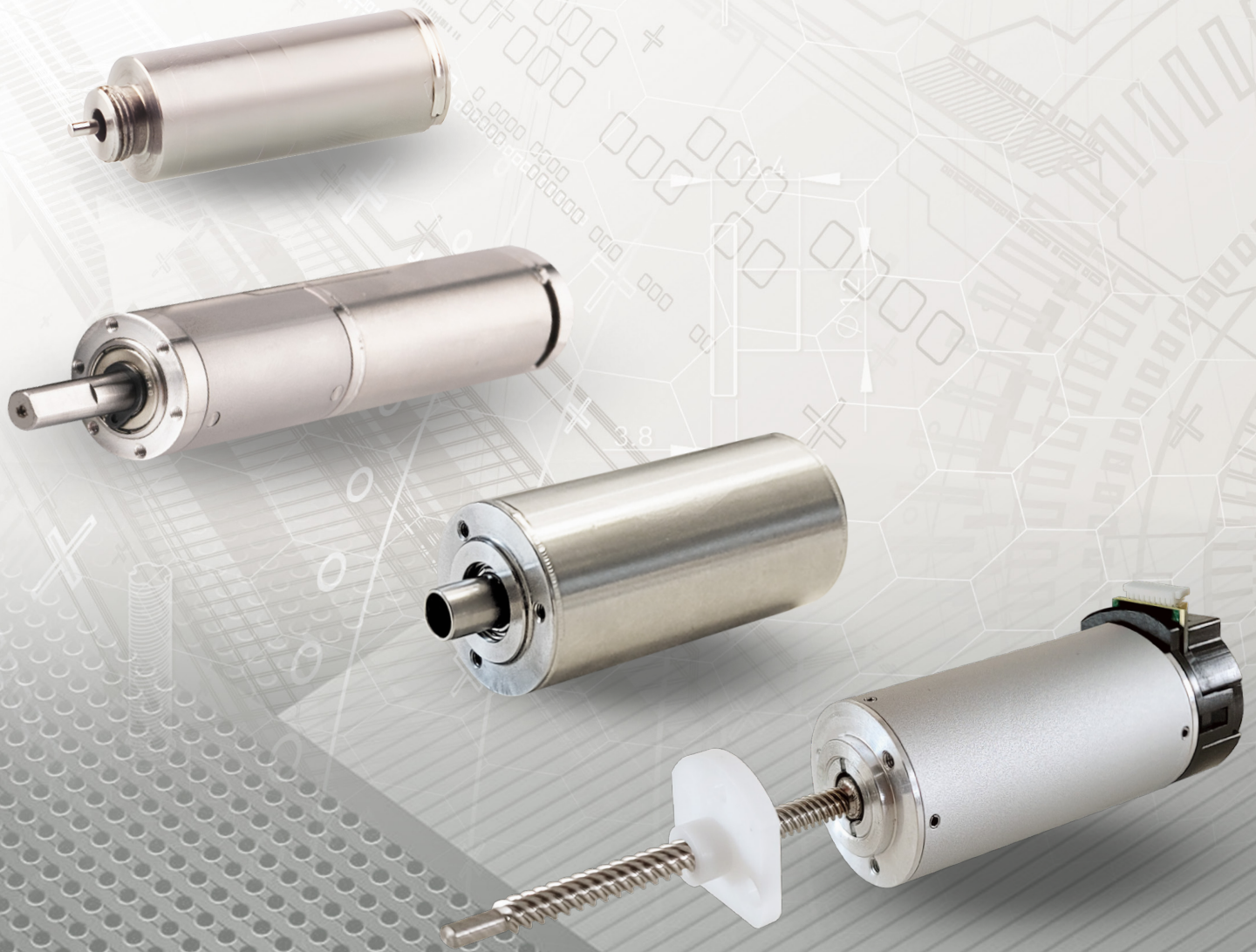

DINGS' Slotless Brushless DC Motors can avoid the pulsation of air gap magnetic induction caused by uneven magnetic resistance in the teeth.

It can eliminate the pulse loss in the armature core and the surface loss on the main pole surface.

Slotless Brushless DC Motor has high durability, low electrical noise and high efficiency. Maximum efficiency of motor reaches 91% and this motor is suitable for the servo system which needs quick movement and high power.

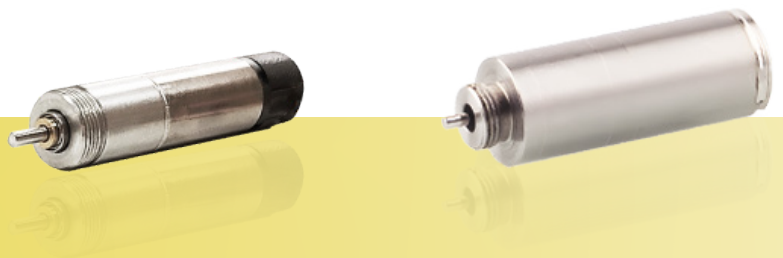

SLOTLESS BLDC MOTOR

CONTENTS

Part number construction

10 mm

16 mm

22 mm

28 mm

30 mm

36 mm

42 mm

Precision planetary gearbox



Part Number Construction

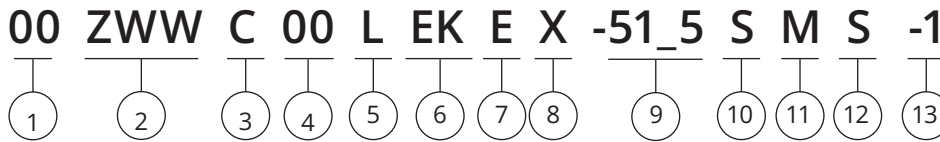

① Motor Size

Motor Size(mm)	10	16	22	28	30	36	42
----------------	----	----	----	----	----	----	----

② Product Name

ZWW = Slotless Brushless DC Motor

③ Motor Shape

C = Circular Type

S = Square Type

④ Motor Length

Unit : mm

when the length involves decimal points, use "_" instead

⑤ Motor Casing

L = Aluminum

T = Stainless steel / Iron

X = Inorganic Shell

⑥ Option

EKX = Encoder (X = Encoder Resolution)

B = Brake

GX= Gearbox (X = Gear Ratio)

Note: When Options are not single,

please use in alphabetical order for example, "BEG"

⑦ Structure

E = External type

N = Non-Captive type

C = Electric Cylinder (Captive) type

K = Kaptive type

⑧ Lead Screw Code

Please refer to lead screw code selection table

⑨ Screw Length / Stroke

Kaptive = stroke distance

Non-captive = total length of screw

External = screw extension length from the mounting flange

⑩ Screw Surface Treatment

T = Teflon coating

S = Standard (No teflon coating)

⑪ End Machining

M = Metric

U = UNC

S = Smooth

C = Customize

N = None

⑫ Nut style

S = Standard Flange Nut

A = Anti-Backlash Nut

C = Customized Nut

⑬ Customer Sequence Number

Example

Part Number

16ZWWC38EK-001

Description

Motor diameter 16mm
Slotless BLDC circular type
Body length 38mm
Encoder
Customizaion No.001

10mm Slotless BLDC

Motor Characteristics

Motor part number		10ZWWC25
Pole pair	-	1
Phase resistance	Ω	4.3
Winding connection method	-	Star shape
Insulation class	-	B
Duty type	-	S1
Commutation angle	-	120°
Insulation strength (Withstand voltage)	-	500VAC/1KHz/1mA/1s
Insulation resistance	-	100 M Ω /500VDC
Weight	g	10.6
Rated voltage	V	12
Rated power	W	4.9
Rated torque	mN·m	1.5
Rated speed	RPM	31000
Rated current	A	0.8
No load speed	RPM	40000
No load current	A	0.05
Motor efficiency	%	75
Noise (Ambient noise 20db, test distance 1m)	dB	<50
Torque constant	mN·m/A	1.88
Back-EMF constant - peak value	V/Krpm	0.46
Back-EMF constant - effective value	V/Krpm	0.32
Peak torque	mN·m	4.5
Peak current	A	2.4
Inertia moment	g·cm ²	0.026
Mechanical time constant	ms	3.18
End bell	-	Stainless steel
Bearing	-	Deep Groove Ball bearing
Magnet	-	Sinter NdFeB
Rotation shaft	-	Carbon steel

10mm Slotless BLDC

Dimensional Drawings

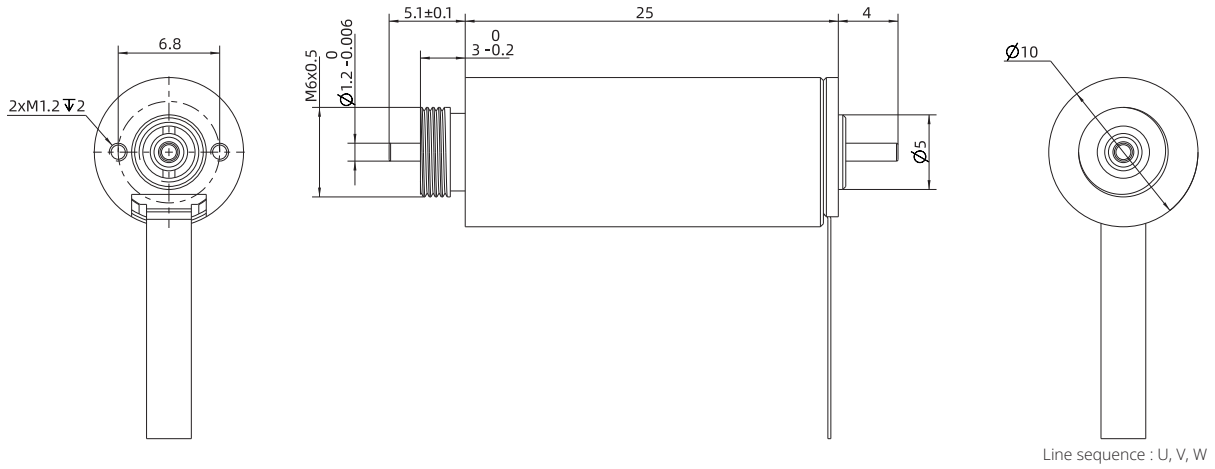

Torque Performance Curves

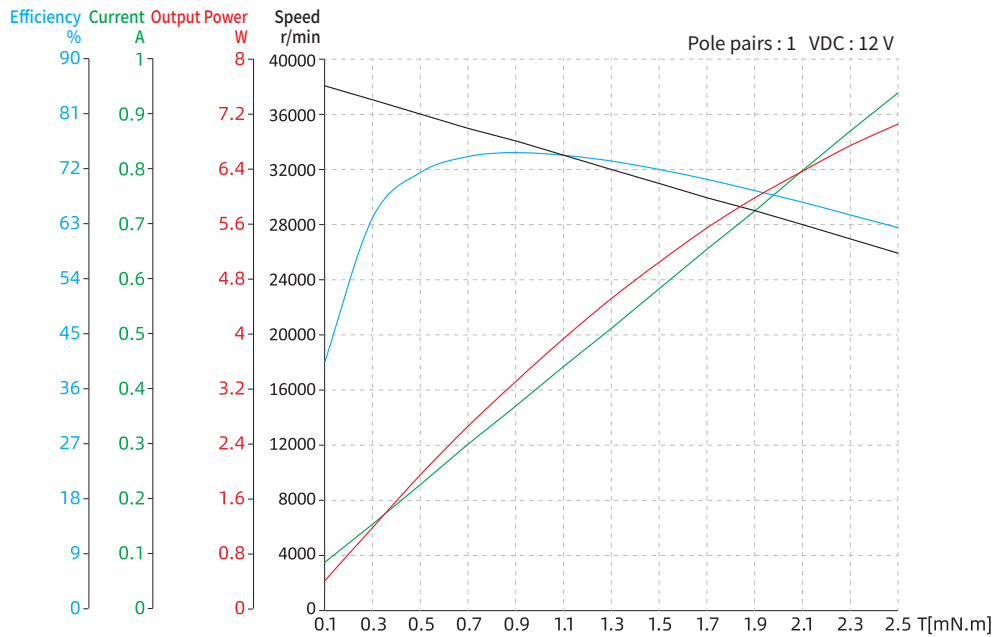

16mm Slotless BLDC

Motor Characteristics

Motor part number		16ZWWC40			
Pole pair	-	1	1	1	1
Phase resistance	Ω	0.63	1.31	1.85	3.15
Phase inductance	mH	0.033	0.045	0.096	0.2
Winding connection method	-	Star shape	Star shape	Star shape	Star shape
Insulation class	-	B	B	B	B
Duty type	-	S2	S2	S2	S2
Feedback method	-	Hall sensors	Hall sensors	Hall sensors	Hall sensors
Commutation angle	-	120°	120°	120°	120°
Insulation strength (Withstand voltage)	-	500VAC/1KHz/ 1mA/1s	500VAC/1KHz/ 1mA/1s	500VAC/1KHz/ 1mA/1s	500VAC/1KHz/ 1mA/1s
Insulation resistance	-	100 MΩ/500VDC	100 MΩ/500VDC	100 MΩ/500VDC	100 MΩ/500VDC
Weight	g	47	47	47	47
Rated voltage	V	18	24	36	48
Rated power	W	33	39	39	39
Rated torque	mN·m	7.4	7.4	7.5	7.4
Rated speed	RPM	44000	51300	50000	50000
Rated current	A	2.19	1.96	1.32	0.95
No load speed	RPM	50000	58000	56000	56000
No load current	A	0.31	0.22	0.15	0.12
Motor efficiency	%	85	84	82.4	84.92
Noise (Ambient noise 20db, test distance 1m)	dB	<50	<50	<50	<50
Case - Environmental thermal resistance (no load)	K/W	1.22	1.33	1.47	1.07
Motor thermal time constant (no load)	S	420	450	480	390
Ambient temperature	°C	22.3	22.3	22.3	22.3
Max. winding temperature (no load)	°C	63	75	80	63.8
Torque constant	mN·m/A	3.38	3.78	5.66	7.75
Back-EMF constant - peak value	V/Krpm	0.50	0.56	0.84	1.15
Back-EMF constant - effective value	V/Krpm	0.35	0.40	0.59	0.81
Peak torque	mN·m	96.65	69.21	110.19	118.13
Peak current	A	29	18	19	15
Inertia moment	g·cm ²	0.583	0.583	0.583	0.583
Mechanical time constant	ms	3.21	5.35	3.36	3.06
End bell	-	Stainless steel	Stainless steel	Stainless steel	Stainless steel
Bearing	-	Deep Groove Ball bearing	Deep Groove Ball bearing	Deep Groove Ball bearing	Deep Groove Ball bearing
Magnet	-	Sinter NdFeB	Sinter NdFeB	Sinter NdFeB	Sinter NdFeB
Rotation shaft	-	Carbon steel	Carbon steel	Carbon steel	Carbon steel

16mm Slotless BLDC

Dimensional Drawings

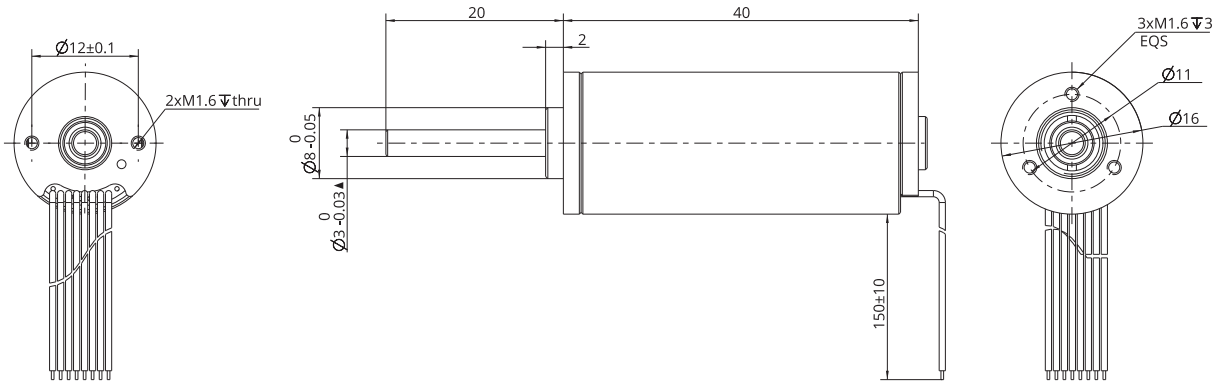

Torque Performance Curves

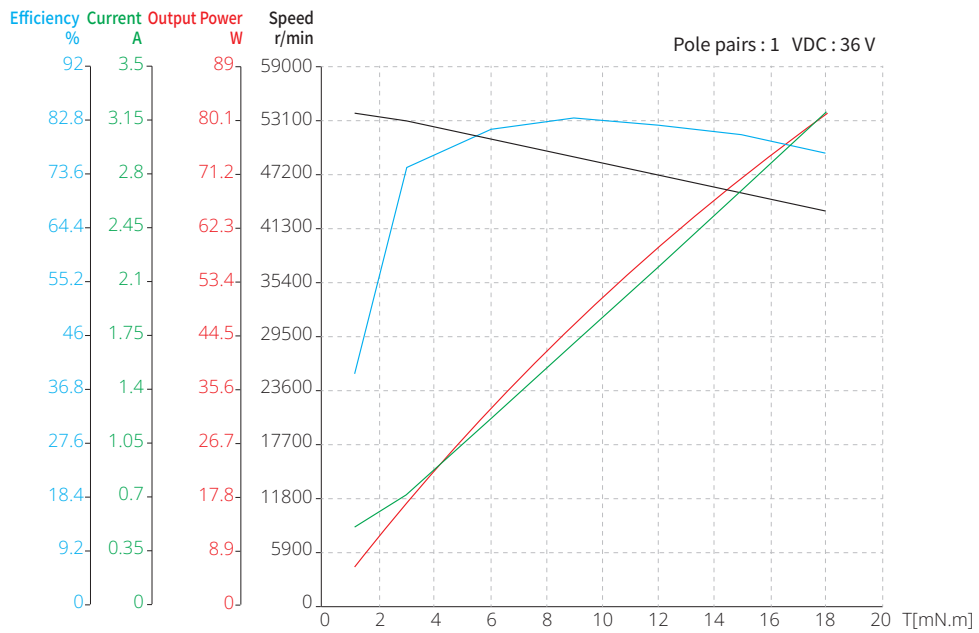

22mm Slotless BLDC

Motor Characteristics

Motor part number		22ZWWC48				
Pole pair	-	1	1	1	1	2
Phase resistance	Ω	0.26	0.3	0.57	1	0.94
Phase inductance	mH	0.018	0.027	0.06	0.11	0.057
Winding connection method	-	Star shape	Star shape	Star shape	Star shape	Star shape
Insulation class	-	B	B	B	B	B
Duty type	-	S2	S2	S2	S2	S1
Feedback method	-	Hall sensors	Hall sensors	Hall sensors	Hall sensors	Hall sensors
Commutation angle	-	120°	120°	120°	120°	120°
Insulation strength (Withstand voltage)	-	500VAC/1KHz/ 1mA/1s	500VAC/1KHz/ 1mA/1s	500VAC/1KHz/ 1mA/1s	500VAC/1KHz/ 1mA/1s	500VAC/1KHz/ 1mA/1s
Insulation resistance	-	100 MΩ/500VDC	100 MΩ/500VDC	100 MΩ/500VDC	100 MΩ/500VDC	100 MΩ/500VDC
Weight	g	110	110	110	110	110
Rated voltage	V	18	24	36	48	24
Rated power	W	83	100	100	100	53
Rated torque	mN·m	20	20	20	20	25
Rated speed	RPM	40000	49000	47400	49600	20100
Rated current	A	7.95	4.68	3.12	2.29	3.00
No load speed	RPM	50000	55000	53000	54000	25700
No load current	A	0.3	0.4	0.32	0.14	0.18
Motor efficiency	%	87	89	89	91	81
Noise (Ambient noise 20db, test distance 1m)	dB	<50	<50	<50	<50	<50
Case - Environmental thermal resistance (no load)	K/W	0.38	0.58	0.51	0.42	1.12
Motor thermal time constant (no load)	S	840	600	900	1200	620
Ambient temperature	°C	21.4	22	24.7	21.1	23.3
Max. winding temperature (no load)	°C	52.7	80	75.5	70.5	82
Torque constant	mN·m/A	2.52	4.27	6.41	8.74	8.33
Back-EMF constant - peak value	V/Krpm	0.37	0.63	0.95	1.29	1.23
Back-EMF constant - effective value	V/Krpm	0.26	0.45	0.67	0.91	0.87
Peak torque	mN·m	116.11	341.76	404.72	419.33	212.77
Peak current	A	46	80	63	48	26
Inertia moment	g·cm ²	1.15	1.15	1.15	1.15	1.15
Mechanical time constant	ms	4.72	1.89	1.60	1.51	1.56
End bell	-	Stainless steel	Stainless steel	Stainless steel	Stainless steel	Stainless steel
Bearing	-	Deep Groove Ball bearing	Deep Groove Ball bearing	Deep Groove Ball bearing	Deep Groove Ball bearing	Deep Groove Ball bearing
Magnet	-	Sinter NdFeB	Sinter NdFeB	Sinter NdFeB	Sinter NdFeB	Sinter NdFeB
Rotation shaft	-	Carbon steel	Carbon steel	Carbon steel	Carbon steel	Carbon steel

For stroke customization, please contact DINGS' or local representative.

22mm Slotless BLDC

Dimensional Drawings

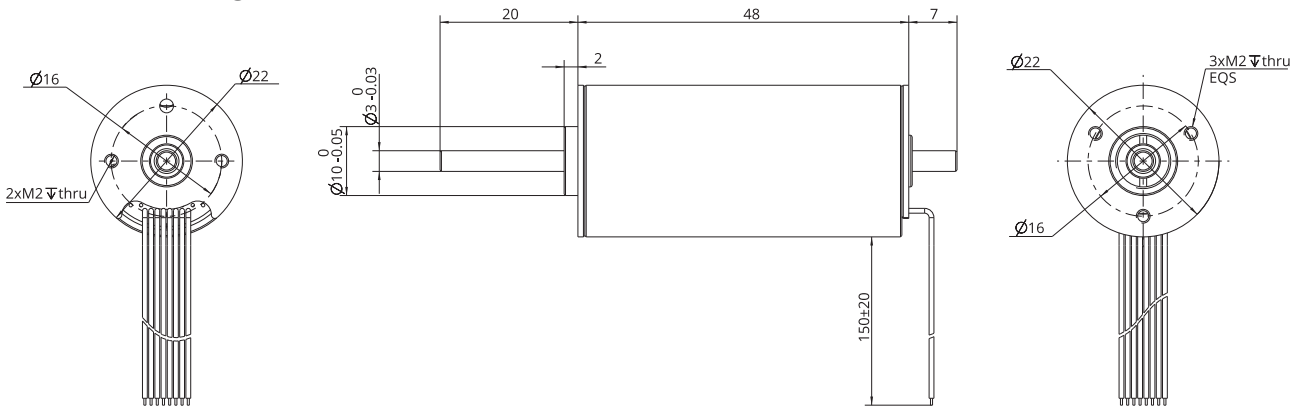

Torque Performance Curves

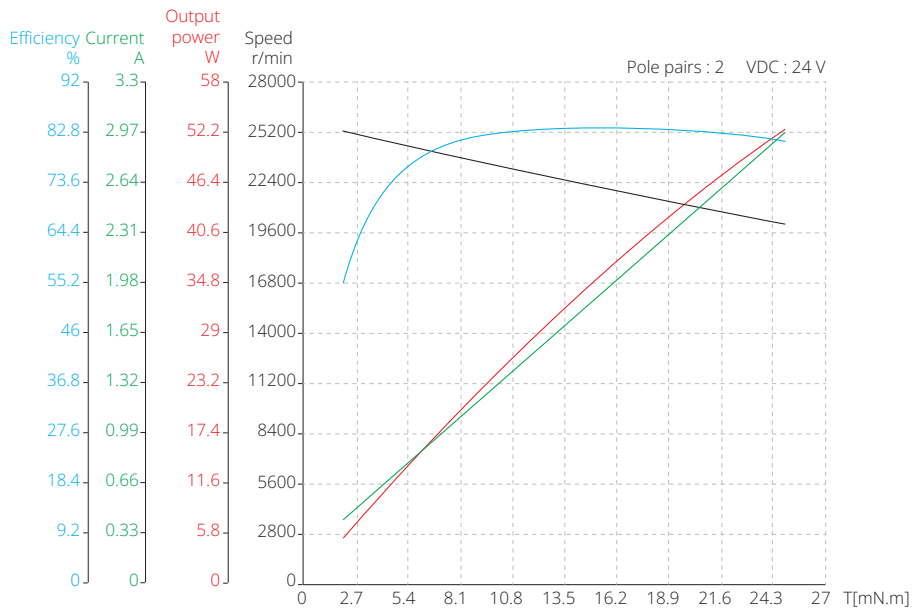
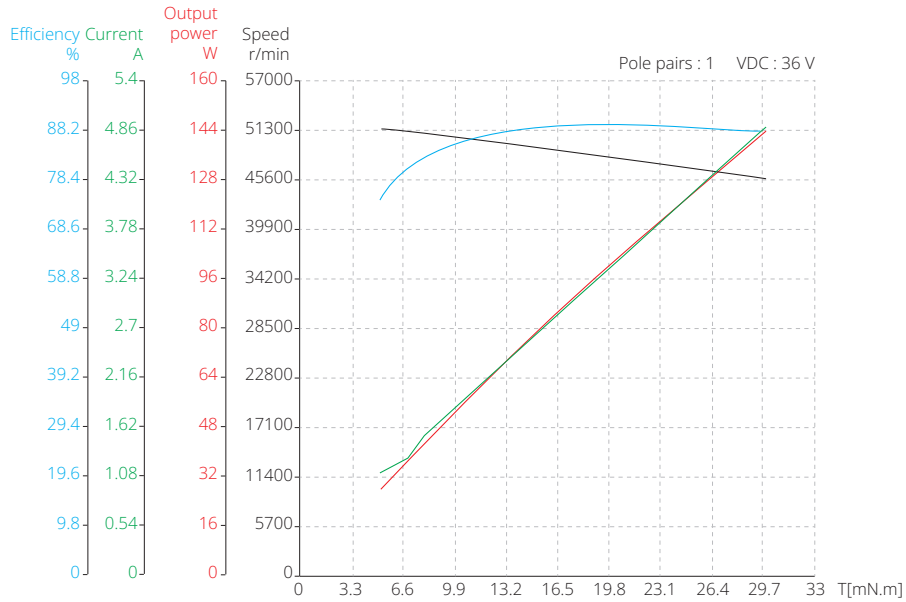

28mm Slotless BLDC

Motor Characteristics

Motor part number		28ZWWC52				
Pole pair	-	1	1	1	1	2
Phase resistance	Ω	0.52	1.7	4.3	6.6	1.6
Phase inductance	mH	0.0495	0.178	0.42	0.77	0.13
Winding connection method	-	Star shape	Star shape	Star shape	Star shape	Star shape
Insulation class	-	B	B	B	B	B
Duty type	-	S2	S2	S2	S2	S1
Feedback method	-	Hall sensors	Hall sensors	Hall sensors	Hall sensors	Hall sensors
Commutation angle	-	120°	120°	120°	120°	120°
Insulation strength (Withstand voltage)	-	500VAC/1KHz/ 1mA/1s	500VAC/1KHz/ 1mA/1s	500VAC/1KHz/ 1mA/1s	500VAC/1KHz/ 1mA/1s	500VAC/1KHz/ 1mA/1s
Insulation resistance	-	100 MΩ/500VDC	100 MΩ/500VDC	100 MΩ/500VDC	100 MΩ/500VDC	100 MΩ/500VDC
Weight	g	170	170	170	170	170
Rated voltage	V	12	24	36	48	24
Rated power	W	30	34	35	35	37
Rated torque	mN·m	32	32	32	34	50
Rated speed	RPM	6970	8430	8370	8340	7000
Rated current	A	3.13	1.69	1.17	0.86	2.00
No load speed	RPM	9270	9680	9500	9400	8500
No load current	A	0.2	0.11	0.084	0.061	0.12
Motor efficiency	%	80	84	83	85	81.5
Noise (Ambient noise 20db, test distance 1m)	dB	<50	<50	<50	<50	<50
Case - Environmental thermal resistance (no load)	K/W	0.67	0.69	0.73	0.64	0.70
Motor thermal time constant (no load)	S	1200	1200	1080	1100	880
Ambient temperature	°C	23	24	27	25	21.2
Max. winding temperature (no load)	°C	43.2	47.3	52.5	47.4	46.7
Torque constant	mN·m/A	10.24	18.97	27.32	39.63	25
Back-EMF constant - peak value	V/Krpm	1.52	2.81	4.04	5.87	3.70
Back-EMF constant - effective value	V/Krpm	1.07	1.99	2.86	4.15	2.62
Peak torque	mN·m	236.31	267.87	228.72	288.25	375
Peak current	A	23	14	8	7	15
Inertia moment	g·cm ²	10.2	10.2	10.2	10.20	10.2
Mechanical time constant	ms	5.06	4.82	5.88	4.29	2.61
End bell	-	Stainless steel	Stainless steel	Stainless steel	Stainless steel	Stainless steel
Bearing	-	Deep Groove Ball bearing	Deep Groove Ball bearing	Deep Groove Ball bearing	Deep Groove Ball bearing	Deep Groove Ball bearing
Magnet	-	Sinter NdFeB	Sinter NdFeB	Sinter NdFeB	Sinter NdFeB	Sinter NdFeB
Rotation shaft	-	Carbon steel	Carbon steel	Carbon steel	Carbon steel	Carbon steel

For stroke customization, please contact DINGS' or local representative.

28mm Slotless BLDC

Dimensional Drawings

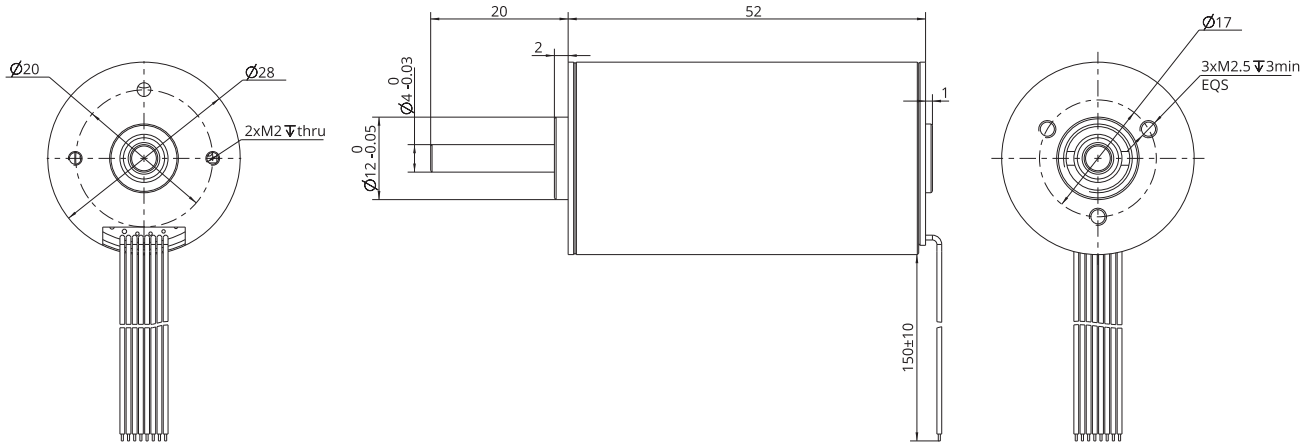

Torque Performance Curves

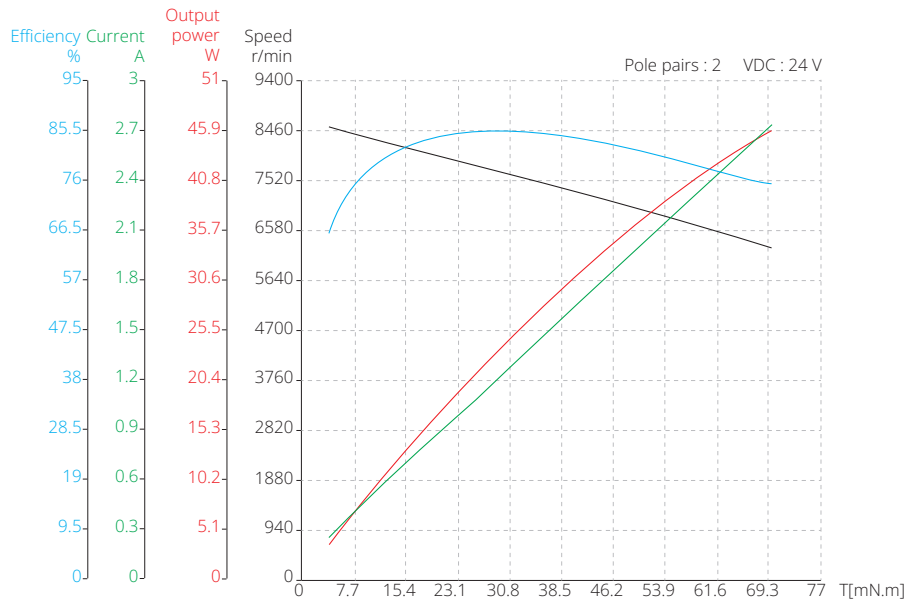
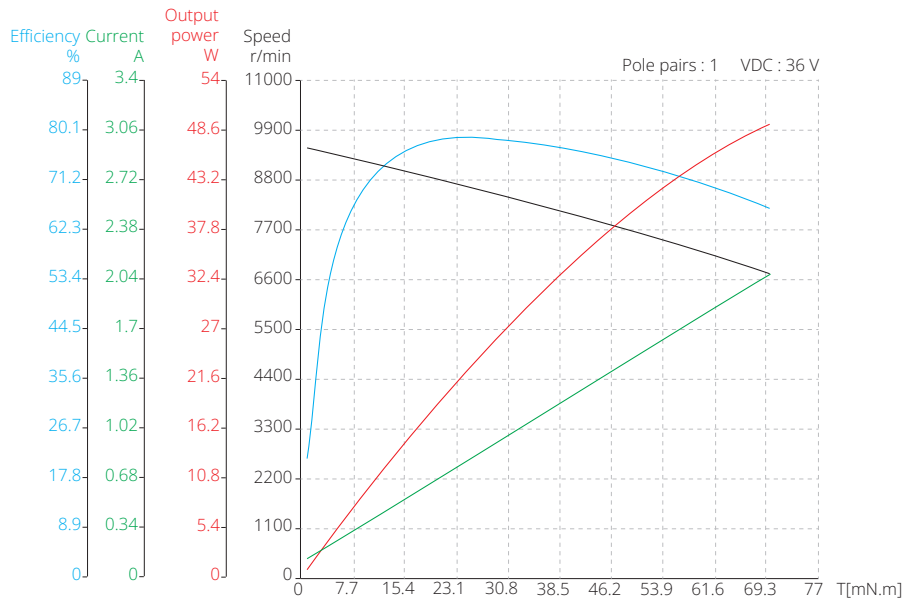

30mm Slotless BLDC

Motor Characteristics

Motor part number		30ZWWC65
Pole pair	-	2
Phase resistance	Ω	0.5
Phase inductance	mH	0.05
Winding connection method	-	Star shape
Insulation class	-	B
Duty type	-	S1
Feedback method	-	Hall sensors
Commutation angle	-	120°
Insulation strength (Withstand voltage)	-	500VAC/1KHz/1mA/1s
Insulation resistance	-	100 M Ω /500VDC
Weight	g	230
Rated voltage	V	24
Rated power	W	65
Rated torque	mN·m	90
Rated speed	RPM	6900
Rated current	A	3.85
No load speed	RPM	9200
No load current	A	0.3
Motor efficiency	%	86
Noise (Ambient noise 20db, test distance 1m)	dB	<50
Case - Environmental thermal resistance (no load)	K/W	0.31
Motor thermal time constant (no load)	S	1200
Ambient temperature	°C	23
Max. winding temperature (no load)	°C	43.2
Torque constant	mN·m/A	23.38
Back-EMF constant - peak value	V/Krpm	3.46
Back-EMF constant - effective value	V/Krpm	2.45
Peak torque	mN·m	1122.08
Peak current	A	48
Inertia moment	g·cm ²	28
Mechanical time constant	ms	2.56
End bell	-	Stainless steel
Bearing	-	Deep Groove Ball bearing
Magnet	-	Sinter NdFeB
Rotation shaft	-	Carbon steel

30mm Slotless BLDC

Dimensional Drawings

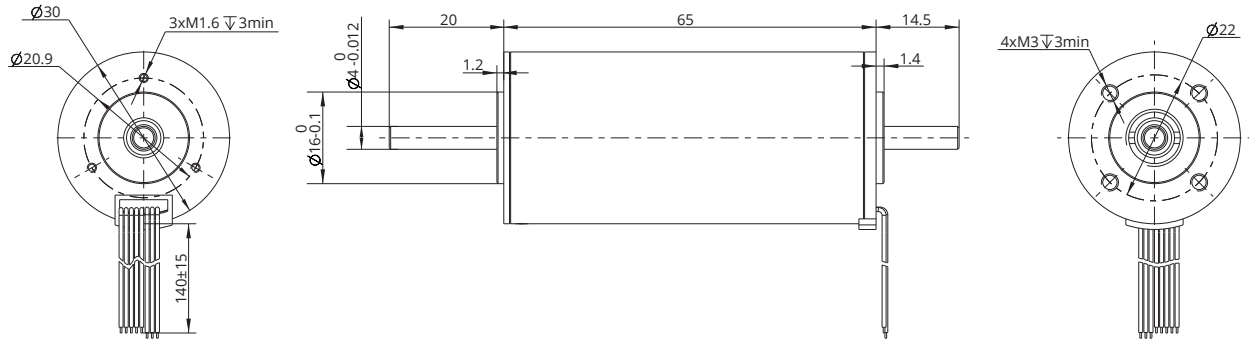

Torque Performance Curves

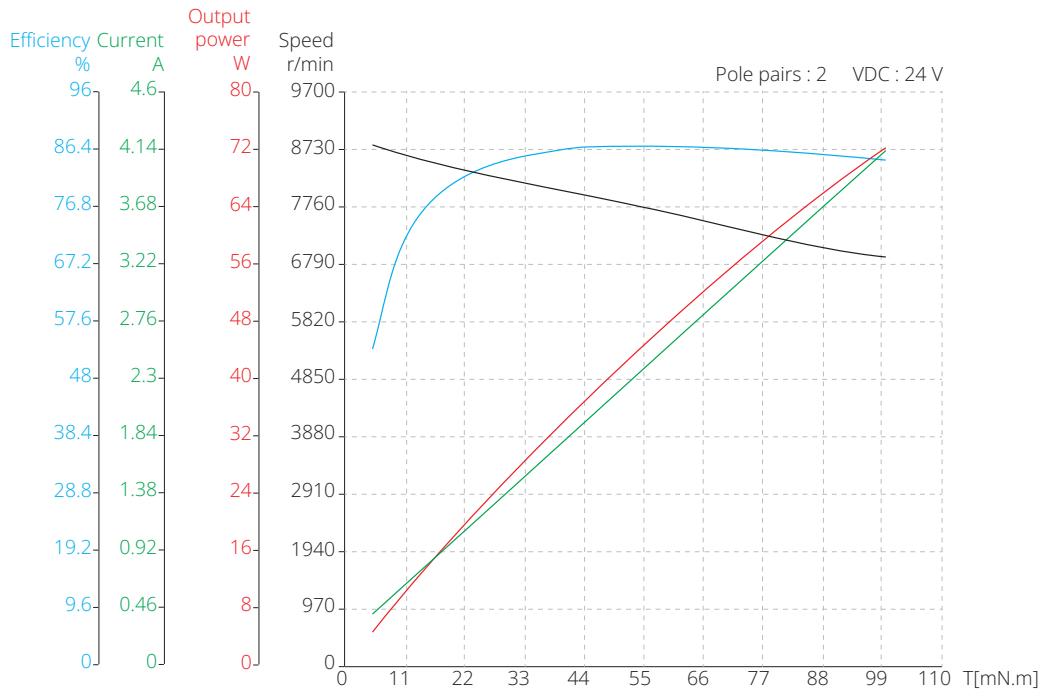

36mm Slotless BLDC

Motor Characteristics

Motor part number		36ZWWC60				
Pole pair	-	1	1	1	1	2
Phase resistance	Ω	0.6	0.68	1.45	2.1	0.41
Phase inductance	mH	0.08	0.1	0.19	0.27	0.042
Winding connection method	-	Star shape	Star shape	Star shape	Star shape	Star shape
Insulation class	-	B	B	B	B	B
Duty type	-	S2	S2	S2	S2	S1
Feedback method	-	Hall sensors	Hall sensors	Hall sensors	Hall sensors	Hall sensors
Commutation angle	-	120°	120°	120°	120°	120°
Insulation strength (Withstand voltage)	-	500VAC/1KHz/ 1mA/1s	500VAC/1KHz/ 1mA/1s	500VAC/1KHz/ 1mA/1s	500VAC/1KHz/ 1mA/1s	500VAC/1KHz/ 1mA/1s
Insulation resistance	-	100 MΩ/500VDC	100 MΩ/500VDC	100 MΩ/500VDC	100 MΩ/500VDC	100 MΩ/500VDC
Weight	g	270	270	270	270	270
Rated voltage	V	18	24	36	48	24
Rated power	W	68	69	74	85	85
Rated torque	mN·m	70	70	70	70	100
Rated speed	RPM	7340	9345	10000	11700	8100
Rated current	A	4.97	3.78	2.59	2.21	4.80
No load speed	RPM	10000	11000	11500	13000	10300
No load current	A	0.37	0.37	0.22	0.2	0.36
Motor efficiency	%	76	76	79.5	80	84.4
Noise (Ambient noise 20db, test distance 1m)	dB	<50	<50	<50	<50	<50
Case - Environmental thermal resistance (no load)	K/W	0.42	0.43	0.44	0.36	0.58
Motor thermal time constant (no load)	S	1350	1350	2700	1080	1330
Ambient temperature	°C	21.1	23.1	20.1	20.4	19.5
Max. winding temperature (no load)	°C	49.4	52.9	52.8	50.8	69.3
Torque constant	mN·m/A	14.08	18.50	27.07	31.62	20.83
Back-EMF constant - peak value	V/Krpm	2.09	2.74	4.01	4.68	3.08
Back-EMF constant - effective value	V/Krpm	1.47	1.94	2.83	3.31	2.18
Peak torque	mN·m	422.47	653.09	672.16	722.82	1219.51
Peak current	A	30	35	25	23	59
Inertia moment	g·cm ²	39	39	39	39	39
Mechanical time constant	ms	11.80	7.75	7.72	8.19	3.68
End bell	-	Stainless steel	Stainless steel	Stainless steel	Stainless steel	Stainless steel
Bearing	-	Deep Groove Ball bearing	Deep Groove Ball bearing	Deep Groove Ball bearing	Deep Groove Ball bearing	Deep Groove Ball bearing
Magnet	-	Sinter NdFeB	Sinter NdFeB	Sinter NdFeB	Sinter NdFeB	Sinter NdFeB
Rotation shaft	-	Carbon steel	Carbon steel	Carbon steel	Carbon steel	Carbon steel

For stroke customization, please contact DINGS' or local representative.

36mm Slotless BLDC

Dimensional Drawings

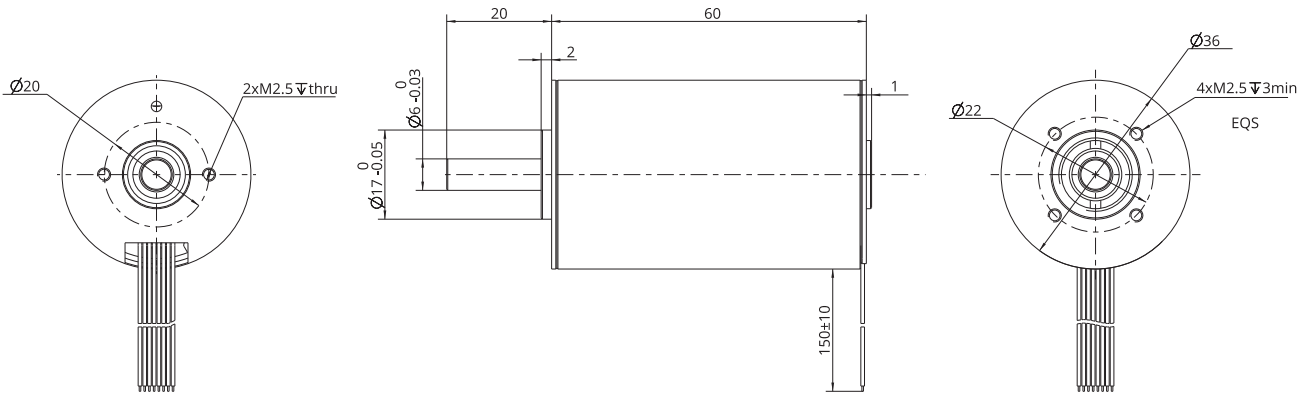

Torque Performance Curves

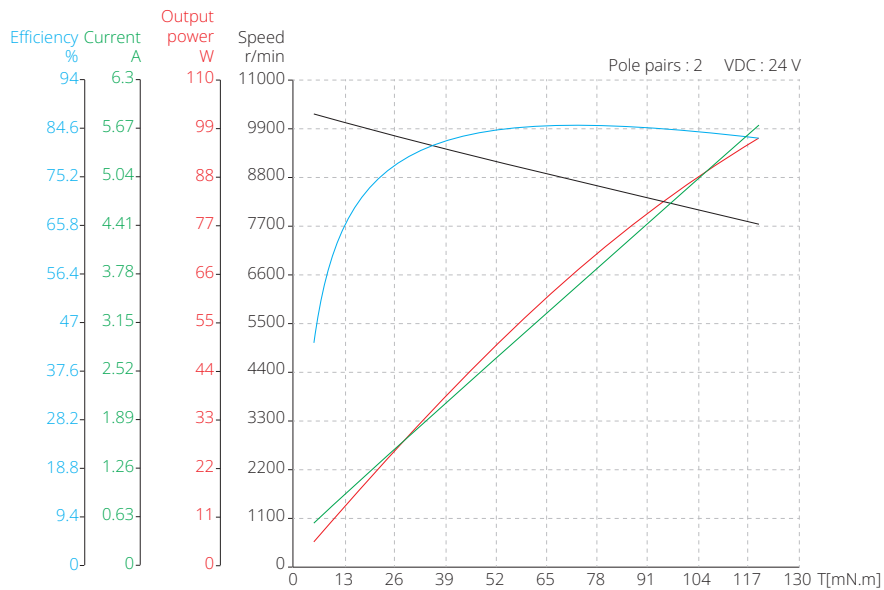
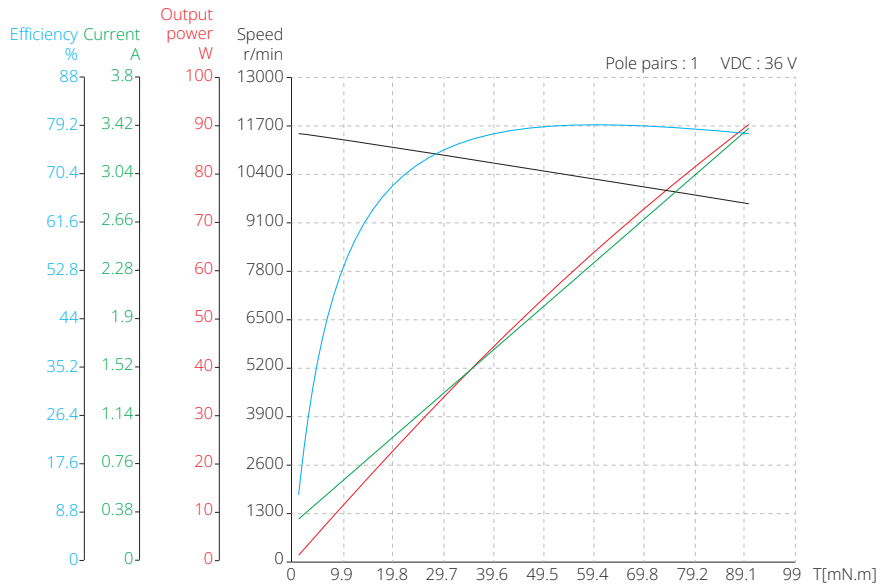

42mm Slotless BLDC

Motor Characteristics

Motor part number		42ZWWC80				
Pole pair	-	1	1	1	1	2
Phase resistance	Ω	0.4	0.45	0.6	0.95	0.22
Phase inductance	mH	0.085	0.14	0.14	0.23	0.035
Winding connection method	-	Star shape	Star shape	Star shape	Star shape	Star shape
Insulation class	-	B	B	B	B	B
Duty type	-	S2	S2	S2	S2	S1
Feedback method	-	Hall sensors	Hall sensors	Hall sensors	Hall sensors	Hall sensors
Commutation angle	-	120°	120°	120°	120°	120°
Insulation strength (Withstand voltage)	-	500VAC/1KHz/1mA/1s	500VAC/1KHz/1mA/1s	500VAC/1KHz/1mA/1s	500VAC/1KHz/1mA/1s	500VAC/1KHz/1mA/1s
Insulation resistance	-	100 MΩ/500VDC	100 MΩ/500VDC	100 MΩ/500VDC	100 MΩ/500VDC	100 MΩ/500VDC
Weight	g	500	500	500	500	500
Rated voltage	V	18	24	36	48	24
Rated power	W	66	80	100	160	102
Rated torque	mN·m	90	90	90	120	180
Rated speed	RPM	6678	8346	11619	12200	5400
Rated current	A	4.89	4.17	3.47	4.17	5.70
No load speed	RPM	9000	11000	13000	13800	6800
No load current	A	0.6	0.69	0.6	0.58	0.42
Motor efficiency	%	75	80	80	80	87.9
Noise (Ambient noise 20db, test distance 1m)	dB	<50	<50	<50	<50	<50
Case - Environmental thermal resistance (no load)	K/W	0.43	0.50	0.67	0.26	0.41
Motor thermal time constant (no load)	S	900	1620	2040	2040	1340
Ambient temperature	°C	23.1	23.5	23	23	22.6
Max. winding temperature (no load)	°C	51.5	63.7	90	90	72.1
Torque constant	mN·m/A	18.41	21.60	25.92	28.80	31.58
Back-EMF constant - peak value	V/Krpm	2.73	3.20	3.84	4.26	4.68
Back-EMF constant - effective value	V/Krpm	1.93	2.26	2.71	3.02	3.31
Peak torque	mN·m	828.41	1152.00	1555.20	1455.16	3444.98
Peak current	A	45	53	60	51	109
Inertia moment	g·cm ²	96.3	96.3	96.3	96.3	96.3
Mechanical time constant	ms	11.37	9.29	8.60	11.03	2.12
End bell	-	Stainless steel	Stainless steel	Stainless steel	Stainless steel	Stainless steel
Bearing	-	Deep Groove Ball bearing	Deep Groove Ball bearing	Deep Groove Ball bearing	Deep Groove Ball bearing	Deep Groove Ball bearing
Magnet	-	Sinter NdFeB	Sinter NdFeB	Sinter NdFeB	Sinter NdFeB	Sinter NdFeB
Rotation shaft	-	Carbon steel	Carbon steel	Carbon steel	Carbon steel	Carbon steel

For stroke customization, please contact DINGS' or local representative.

42mm Slotless BLDC

Dimensional Drawings

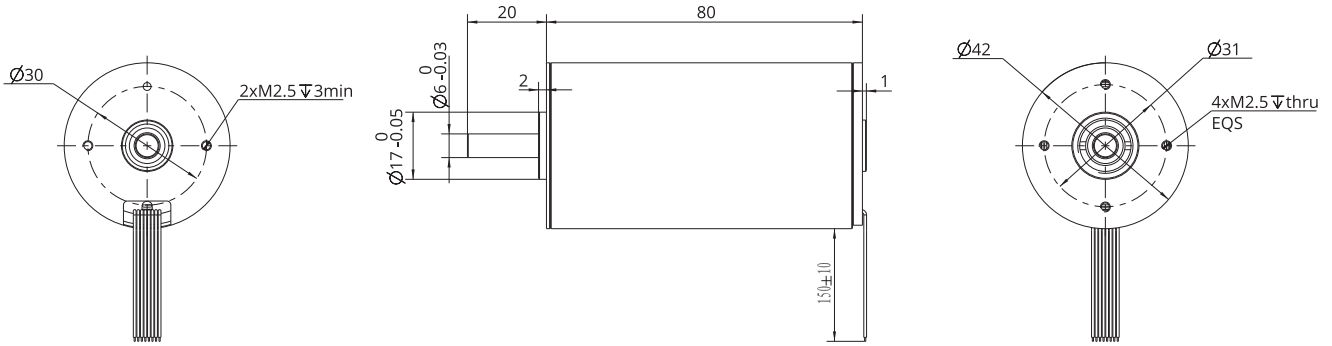

Torque Performance Curves

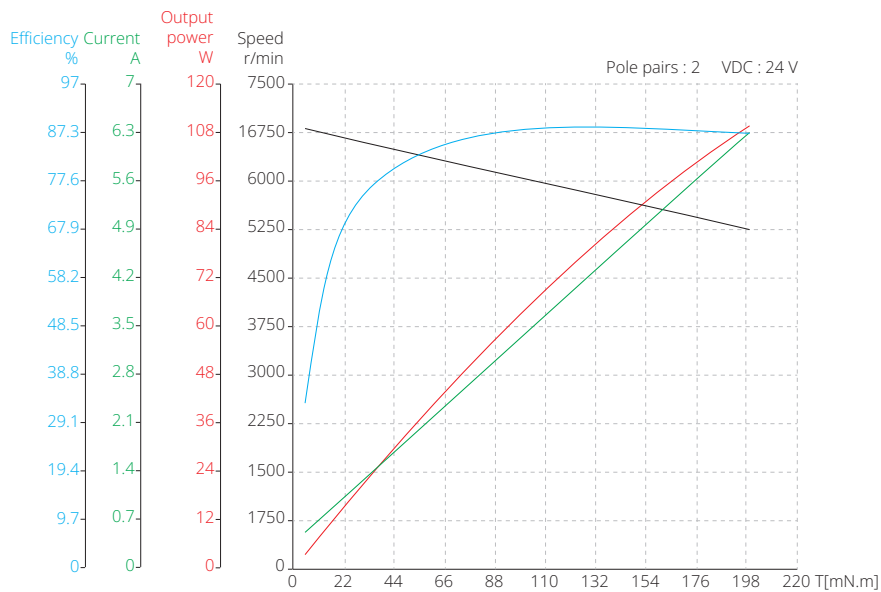
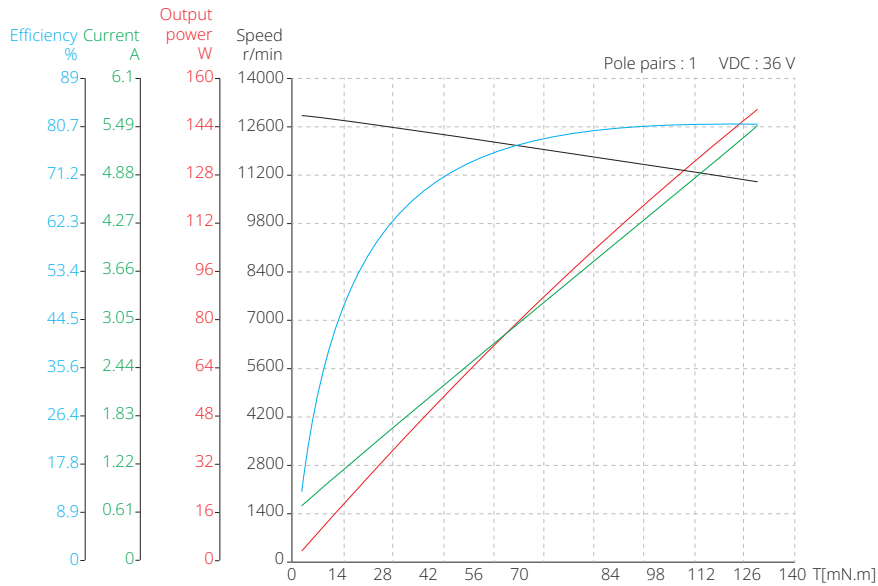

Precision Planetary Gearbox

■ Precision planetary gearbox

● 8PGX

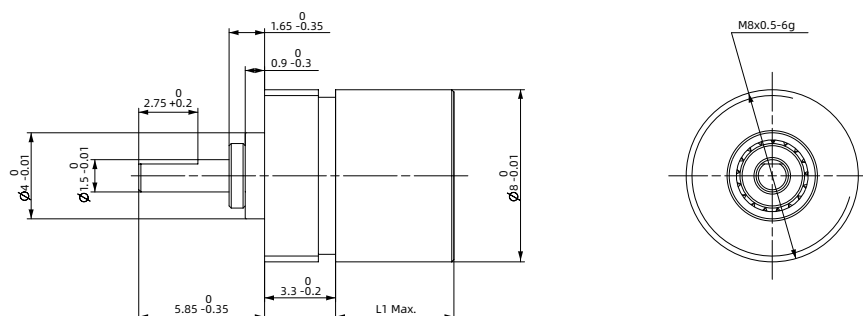

Stage	-	Stage 1	Stage 2
Reduction ratio	X : 1	4	16
Max. continuous torque	N·m	0.01	0.02
Max. continuous output power	W	0.84	0.52
Max. continuous speed transfer	rpm	12000	12000
Max. axial load (Dynamic)	N	5	5
Max. radial load (5mm from flange)	N	5	6
Max. efficiency	%	90	81
Max. backlash	°	1.8	2.0
Gearbox length L	mm	5.5	8.1
Weight	g	2.6	3.2

● 10PGX

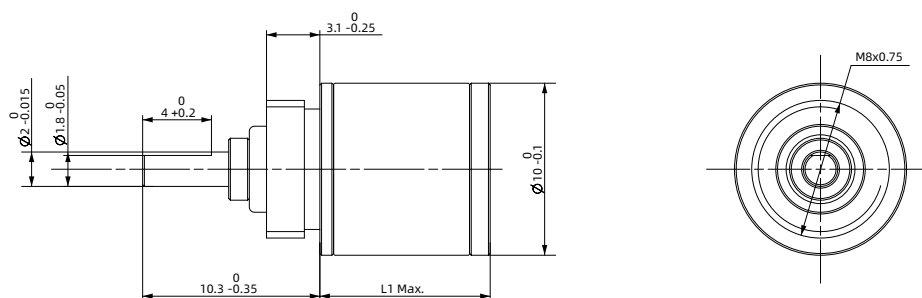

Stage	-	Stage 1	Stage 2	Stage 3	Stage 4
Reduction ratio	X : 1	4.25	18	76.8	326
Max. continuous torque	N·m	0.01	0.03	0.10	0.15
Max. continuous output power	W	1.6	1.2	1.0	0.4
Max. continuous speed transfer	rpm	12000	12000	12000	12000
Max. axial load (Dynamic)	N	5	5	5	5
Max. radial load (5mm from flange)	N	5	10	15	20
Max. efficiency	%	90	81	73	65
Max. backlash	°	1.5	1.8	2.0	2.2
Gearbox length L	mm	10.1	13.6	17.1	20.6
Weight	g	6.7	7.2	7.7	8.2

Precision Planetary Gearbox

● 16PGX

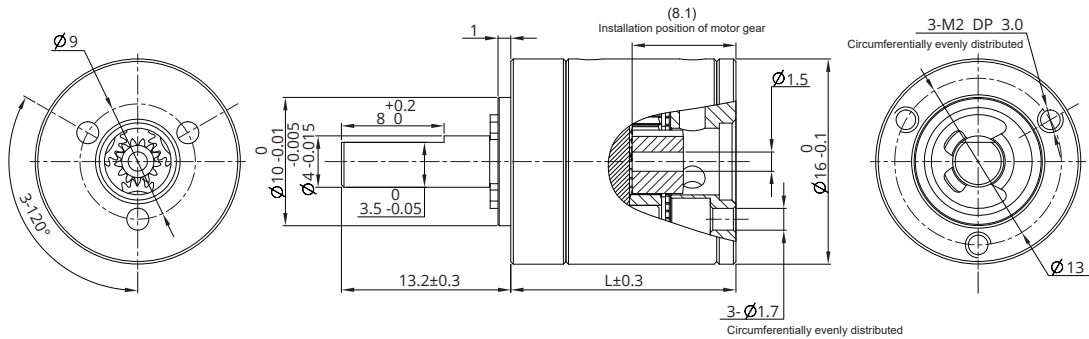

Stage	-	Stage 1	Stage 2	Stage 3	Stage 4
Reduction ratio	X : 1	3.947, 5.307	16, 21, 28	62, 83, 111, 150	243, 326, 439, 590, 794
Max. continuous torque	N·m	0.2	0.25	0.35	0.45
Max. continuous output power	W	6.5	3.2	1.6	0.6
Max. continuous speed transfer	rpm	12000	14000	16000	16000
Max. axial load (Dynamic)	N	20	20	20	20
Max. radial load (5mm from flange)	N	30	45	70	70
Max. efficiency	%	90	80	75	65
Max. backlash	°	1.0	1.2	1.3	1.4
Gearbox length L	mm	18.7	25.5	30.2	35
Weight	g	25	31	37	42

● 22PGX

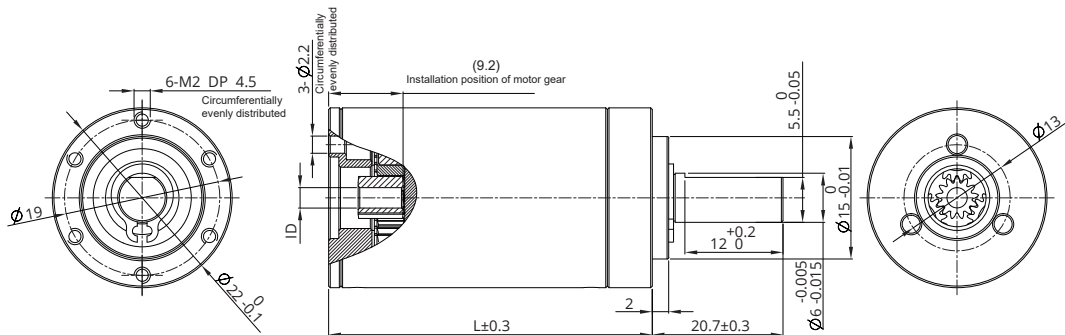

Stage	-	Stage 1	Stage 2	Stage 3	Stage 4
Reduction ratio	X : 1	3.9, 5.3, 6.6	16, 21, 26, 28, 35, 44	62, 83, 103, 111, 138, 150, 172, 186, 231	243, 326, 406, 439, 546, 590, 679, 734, 794, 913, 987, 1135, 1227, 1526
Max. continuous torque	N·m	0.50	0.70	1.20	1.50
Max. continuous output power	W	24	12	6.0	1.6
Max. continuous speed transfer	rpm	8000	10000	12000	12000
Max. axial load (Dynamic)	N	40	40	40	40
Max. radial load (5mm from flange)	N	65	100	120	120
Max. efficiency	%	90	81	74	66
Max. backlash	°	0.85	1.05	1.2	1.35
Gearbox length L	mm	22.3	33	39.6	46.3
Weight	g	59	83	97	112

Precision Planetary Gearbox

● 28PGX

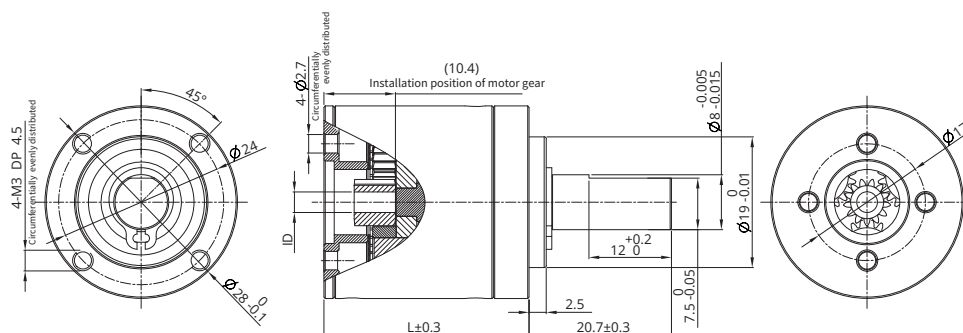

Stage	-	Stage 1	Stage 2	Stage 3	Stage 4
Reduction ratio	X : 1	3.9, 5.3, 6.6	16, 21, 26, 28, 35	62, 83, 103, 111, 138, 150, 172, 186, 231	243, 326, 406, 439, 546, 590, 679, 734, 794, 913, 987, 1135, 1227, 1526
Max. continuous torque	N·m	1.25	2.90	5.0	5.0
Max. continuous output power	W	100	50	25	22
Max. continuous speed transfer	rpm	6000	7000	8000	8000
Max. axial load (Dynamic)	N	110	110	110	110
Max. radial load (5mm from flange)	N	160	180	180	180
Max. efficiency	%	90	81	74	65
Max. backlash	°	0.55	0.7	0.9	1.0
Gearbox length L	mm	24.2	36.9	43.5	50.2
Weight	g	103	150	174	198

● 36PGX

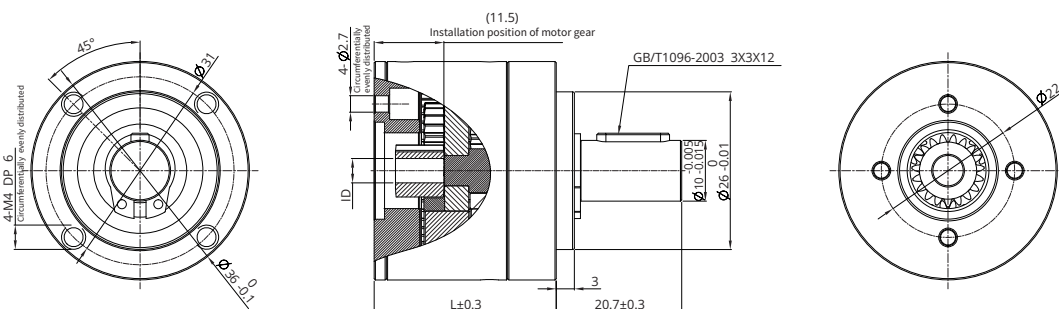

Stage	-	Stage 1	Stage 2	Stage 3	Stage 4
Reduction ratio	X : 1	3.9, 5.3	16, 21, 26, 28, 35	62, 83, 103, 111, 138, 150, 172, 186, 231	243, 326, 406, 439, 546, 590, 679, 734, 794, 913, 987, 1135, 1227, 1526
Max. continuous torque	N·m	2.30	5.40	9.30	9.30
Max. continuous output power	W	185	90	45	40
Max. continuous speed transfer	rpm	5000	6000	7000	7000
Max. axial load (Dynamic)	N	240	240	240	240
Max. radial load (5mm from flange)	N	200	250	250	250
Max. efficiency	%	90	80	75	65
Max. backlash	°	0.5	0.6	0.7	0.8
Gearbox length L	mm	30	44.7	51.3	58
Weight	g	156	238	277	315

Precision Planetary Gearbox

● 42PGX

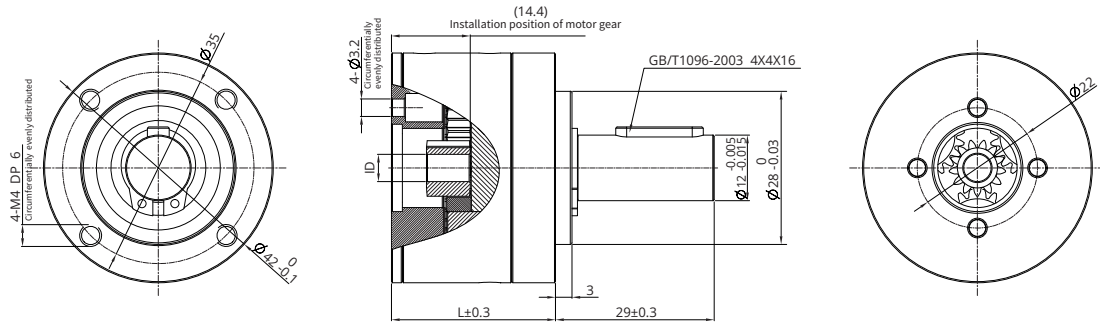

Stage	-	Stage 1	Stage 2	Stage 3	Stage 4
Reduction ratio	X : 1	3.9, 5.3	16, 21, 26, 28, 35	62, 83, 103, 111, 138, 150, 172, 186, 231	243, 326, 406, 439, 546, 590, 679, 734, 794, 913, 987, 1135, 1227, 1526
Max. continuous torque	N·m	3.0	7.5	15	15
Max. continuous output power	W	580	240	100	20
Max. continuous speed transfer	rpm	6000	6000	6000	6000
Max. axial load (Dynamic)	N	200	200	200	200
Max. radial load (5mm from flange)	N	350	525	750	750
Max. efficiency	%	90	81	72	64
Max. backlash	°	0.3	0.4	0.5	0.6
Gearbox length L	mm	36.1	54.9	63.6	72.4
Weight	g	252	405	476	544

DINGS'

Precision Motion Specialist

Headquarter , CHINA

Jiangsu DINGS' Intelligent Control Technology Co., LTD

No. 2850 Luheng Road, Changzhou Economic Development Zone, Jiangsu Province, China

Phone : +86-519-85177826

Fax : +86-519-85177807

E-mail : info@dingsmotion.com

www.dingsmotion.com

Shenzhen Office

Room 1105, Block C, CIMC industry demonstration park, Qiaoming Road, Guangming district, Shenzhen City

E-mail : info@dingsmotion.com

International Office

DINGS' Motion USA

355 Cochrane Circle Morgan Hill, CA 95037

Phone : +1-408-612-4970

E-mail : sales@dingsmotionusa.com

www.dingsmotionusa.com

DINGS' Motion Europe

4 Avenue du Grand Trémoutier 44120 - Vertou - France

Phone : +33-(0)6-41-37-80-07

E-mail : sebastien@dingsmotion.com

<http://fr.dingsmotion.com>

DINGS' KOREA Co., Ltd

C-702, 158, Haneulmaeul-ro, Ilsandong-gu, Goyang-si, Gyeonggi-do, Republic of Korea

Phone : +82-31-994-0755

Fax : +82-70-4325-0755

E-mail : daniel@dingsmotion.com

www.dingsmotion.kr

DINGS' JAPAN

101, 2-27-18, Nishi-kojiya, Ota-ku, Tokyo 144-0034 JAPAN

Phone : +81-3-6811-1335

E-mail : tsukahara@dingsmotion.com

www.dingsmotion.com

■ This catalog is the sole property of DINGS' and without the written authorization of DINGS', any copy or forwarding is prohibited.

■ DINGS' reserves the right to make changes without further notification to any products herein to improve the reliability, function or design.

■ DINGS' reserves the final interpretation.